

2202 Series Overhead Door Magnetic Contacts

Surface/floor mount contacts with armored cable

Overview

The GE Security 2202 Series overhead door magnetic contact is for use in the rigorous environments of commercial and industrial installations.

The floor mount units are constructed with a low profile heavy cast aluminum housing. The reed switch assembly is fully encased in GE Security's exclusive polyurethane potting material to prevent damage due to moisture or humidity. A wide operating gap distance of up to 3 inches makes installation easy and helps prevent false alarms caused by door movement or damaged and loose fitting doors.

The 2202 Series is available with a universal style magnet that allows for greater installation flexibility.



Standard Features

- **Wide 3-inch operating gap**
- **Fully sealed switch**
- **Form C unit available**
- **Mounting hardware included**

2202 Series Overhead Door Magnetic Contacts

Surface/floor mount contacts with armored cable

Specifications

Electrical, 2202

- Voltage: 100 VAC/DC max.
- Current: 0.5 A max.
- Power: 7.5 W max.

Electrical, 2204

- Voltage: 30 VAC/DC max.
- Current: 0.25 A max.
- Power: 3.0 W max.

Features, 2202

- Loop type: Closed
- Electrical configuration: Normally open
- Gap distance: Up to 3 in.
- Lead type: 18 in. flexible stainless steel cable

Features, 2204

- Loop type: Open or closed
- Electrical configuration: SPDT
- Gap distance: Up to 3 in.
- Lead type: 18 in. flexible stainless steel cable
- Lead colors: Black - common; white - closed loop (N.O.); red - open loop (N.C.)

Physical

- Dimensions, 2202A (LxWxD): 3.50 x 1.50 x 1.50 in. (89 x 38 x 38 mm)
- Dimensions, 2202AU and 2204AU (LxWxD): 3.125 x 2.125 x 0.81 in. (79 x 54 x 21 mm)
- Construction: Cast aluminum
- Color: Aluminum

Regulatory

- C-UL-US

Related Diagram

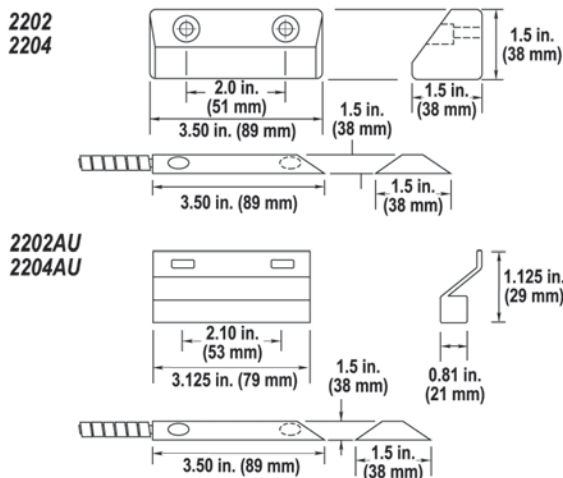

Ordering Information

- 2202A-L Floor-mount magnetic contact for overhead doors, aluminum housing, 3 in. gap size, closed loop, includes 18 in. stainless steel armored cable
- 2202AU-L Floor-mount magnetic contact for overhead doors, universal magnet, 3 in. gap size, closed loop, includes 18 in. stainless steel armored cable
- 2204A-L Floor-mount magnetic contact for overhead doors, aluminum housing, 3 in. gap size, SPDT, includes 18 in. stainless steel armored cable
- 2204AU-L Floor-mount magnetic contact for overhead doors, universal magnet, 3 in. gap size, SPDT, includes 18 in. stainless steel armored cable









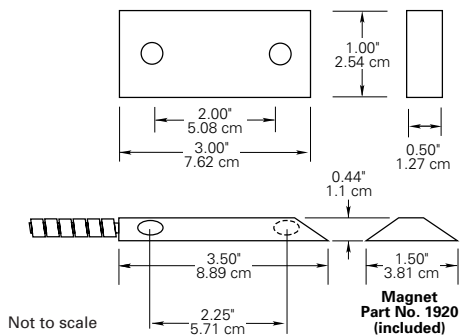
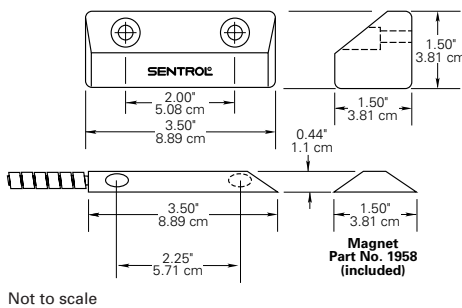
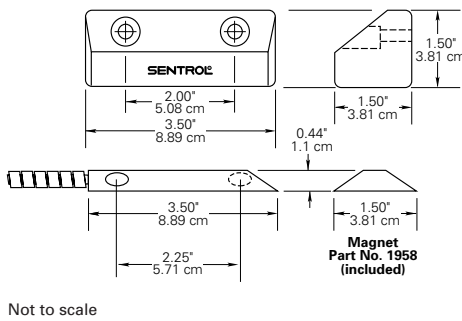
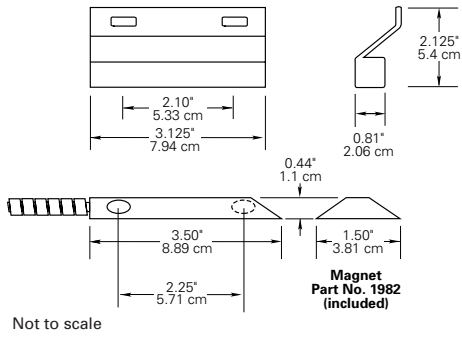

2200 Series

Miniature Surface Mounts With Armored Cable



- Miniature, low-profile design
- Stainless steel armored cable for added security, reliability
- Wide working gap for overhead doors
- Small size less likely to be damaged by forklifts
- Aluminum bar stock resists corrosion in harsh environments
- Mounting hardware included
- Jacketed lead available



| ORDERING INFORMATION | Gap Size | Closed Loop | S.P.D.T. | Lead Type |
|---|----------------|-----------------|-----------------|--------------------------------------|
| Floor Mounting Contact with Universal Magnet   | 3" | 2202AU | 2204AU | 18" Stainless Steel Armored Cable |
| Floor Mounting Contact Aluminum Housing   | 3" | 2202A | 2204A | 18" Stainless Steel Armored Cable |
| Floor Mounting Contact Extra Heavy-duty Aluminum Bar Stock   | 3" | 2205A 2205AU | 2207A 2207AU | 3 foot Stainless Steel Armored Cable |
| Biased for Higher Security Application   | 3/4" to 2 1/2" | | 2207AH* | 3 foot Stainless Steel Armored Cable |

For Accessories, see page 6.39

* Protected by US patent D262,618